



OPERATOR'S MANUAL  
FOR  
XPS3 and XPS2  
HOLOGRAPHIC WEAPON SIGHT (HWS)

See inside cover for distribution statement.

L-3 Eotech Inc. Technical Manual ver. A

JANUARY 2009

DISTRIBUTION STATEMENT: Distribution is authorized to U.S. Government agencies and their contractors. This publication is required for administration and operational purposes. Additional copies of this document can be found on the manufacturer's website. Written requests must be referred to:

L-3 EOTech Service Dept.  
Attn: TM Request  
1201 E. Ellsworth Rd.  
Ann Arbor, MI 48108  
(734)741-8868 x2178  
[general@L-3com.com](mailto:general@L-3com.com)

- This commodity is controlled under the U.S. Department of Commerce's Export Administration Regulations (EAR), ECCN OA987.

## WARNING

**WEAPON SAFETY:** Prior to mounting the HWS on your weapon, be sure the weapon is cleared. If you are not sure how to clear your weapon, please see the accompanying operator's manual for the weapon platform you are mounting the sight on.

**LASER SAFETY:** The HWS is a Class II laser product. The Class II level illuminating beam, however, is completely blocked by the housing. The only laser light accessible to the eye is the image beam and is at a power level within the limit of a Class IIa laser product. The illuminating beam can become accessible to the eye if the housing is broken. Turn the sight off immediately and return the broken unit to the factory for repair.



**FCC COMPLIANCE:** The HWS complies with Part 15 of the FCC Rules. Operation is subject to the following conditions: (1) this device may not cause harmful interference and (2) this device must accept any interference received, including interference that may cause undesired operation.

This page was intentionally left blank.

## CAUTION

- -Never disassemble the sight's optical assembly. The optical cavity is purged, nitrogen filled, and sealed to achieve fog proof performance. Disassembly will void the warranty and render the sight inoperable.
- When using a Night Vision compatible HWS in tandem with an NV device, always check to make sure the sight is off before pressing the NV button to turn on the sight in the Night Vision mode. Otherwise, it will toggle to the Normal mode and saturate the image intensifier.
- When a sudden increase in resistance is felt in the elevation or windage adjustment shafts, the end of the adjustment range has been reached. DO NOT TURN THE ADJUSTMENTS ANY FARTHER OR SERIOUS DAMAGE MAY OCCUR TO THE SIGHT.
- Never clean the glass surface with a dry cloth or paper towel; always dampen the glass surfaces prior to cleaning
- All moving parts of the sight are permanently lubricated. Do not try to lubricate them.
- Do not use deteriorated or corroded batteries. Inspect batteries for rips, tears, dents, or cuts in the housing. If there is any exposed, internal content of the battery, it could affect the operation of the sight.
- The XPS3/XPS2 HWS units are designed to mount directly to either a 1"(25.4mm) weaver or MIL-STD-1913 rail specification.

This page was intentionally left blank.

	Page
1.0 INTRODUCTION .....	1
1.1 General Information .....	1
1.2 Key Attributes .....	2
1.3 Equipment Description .....	5
1.4 Location and Description of Major Components.....	7
2.0 OPERATING INSTRUCTIONS .....	9
2.1 Description of Components, Controls, and Indicators .....	9
2.1.1 Hood.....	10
2.1.2 Batteries .....	10
2.1.3 Replacing Batteries .....	12
2.1.4 Electronic Features .....	13
2.1.5 Night Vision Mode.....	15
2.1.6 Windage and Elevation Adjustments.....	16
2.2 Preventive Maintenance Checks and Services (PMCS).....	18
2.3 Troubleshooting .....	19
2.4 Unit Level Maintenance and Repair .....	23
2.5 Installation of Equipment.....	25
2.6 Zeroing Procedures .....	25

3.0	APPENDIX A, COMPONENTS OF END ITEM .....	29
3.1	Replacement Items.....	29
4.0	APPENDIX B, FACTORY CONTACTS.....	30



## 1.0 INTRODUCTION

### 1.1 General Information

This manual is an overview of the XPS3/XPS2 Holographic Weapon Sight (HWS), and will define the basic operation, features/benefits, and options of this proprietary optical system. The HWS is a state of-the-art optical sighting system, employing holographic sighting technology for small to medium caliber weaponry and launching type platforms. The HWS utilizes holographic optics fabrication technology that is used in the production of advanced heads up display in attack fighter aircraft for targeting, gauge reading, weapon system verification, etc. L-3 EOTech has miniaturized the sophisticated sighting heads up display system into a compact and rugged package for use on small arms and other weapon platforms.

## 1.2 Key Attributes

The XPS3/XPS2 HWS is a lightweight, non-magnifying, optical sight designed for Close Quarter Battle. It allows very fast target acquisition and engagement at short ranges while providing aiming capability out to 300 meters equal to or better than iron sights.

The major combat advantage of the HWS is extremely rapid reticle-on-target acquisition. As quickly as a target is identified, the holographic reticle can be superimposed on the target. The sight allows operators to maintain eye contact on the target and to place the holographic reticle onto the target without shifting focus. Operators can quickly acquire the target and reticle in the same focal plane for fast and accurate shot placement.

The HWS appears to project the holographic image of a reticle on the target plane. The sight can be used as a bright open reticle image or a fine dot which is limited only by the acuity of the shooter's eye. The reticle pattern is parallax free and the holographic heads up display window allows an undistorted and unrestricted view of the target.

The XPS3/XPS2 is offered with one of the following (3) reticle options (see fig. 1):

- 0- 65 minute ring with vertical and horizontal stadia and a 1 MOA aiming dot.
- 1- Single 1 MOA aiming dot (no outer ring)

- 2- 65 minute ring with vertical and horizontal stadia and (2) 1 MOA aiming dots

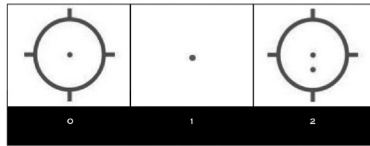

Fig. 1 XPS reticle options

The HWS offers extremely fast target acquisition in Close Quarter Battle (CQB) using the large ring, and aiming precision in longer range engagements (using the MOA Dot) without obscuring the target.

Another advantage of the HWS is the full field of view which allows the operator better situational awareness. The HWS employs a true heads up display (HUD) window that eliminates blind spots and constricted or tunnel vision associated with scope sights. Controls are inset into the HWS housing with no protruding knobs, battery compartments, or rings obscuring the target. Utilizing natural binocular vision is an advantage of this sighting system, as well as additional threat identification through increased operator situational awareness and peripheral vision.

The XPS3 can operate in tandem with Generation I – III+ night vision intensifier tubes. Operators can see the holographic reticle image with helmet mounted or weapon mounted night vision devices. The HWS is a passive system and emits no signature from frontal or from a peripheral aspect. While in the NV mode, the sight is undetectable by opposing force night vision equipment. The HWS can be positioned behind night vision systems without any “bloom” on the target area.

The primary use of the HWS is for the M4A1 carbine and CQBR in Close Quarters Battle. The HWS is not however, limited to carbines. The HWS is currently employed on medium caliber machine guns, grenade launchers and less than lethal projectile launchers. The sight provides a 1X (no magnification) sight picture and is not designed as a long range sight system, however, it can be used as effectively as iron sights on targets to 300 meters.

The advantage of the HWS is that it provides the operator superior shooting performance, rapid reticle-on-target acquisition, full field of view and accurate shot placement. The HWS can be naturally employed by all levels of users, from novice to the most highly trained operator.

### 1.3 XPS3/XPS2 Equipment Description

#### Operation

- Optics: Transmission holography – Parallax free
- Magnification: 1x
- Eye Relief: Unlimited
- Length/Width/Height: 3.75"x2.4"x2.4" (95.25 x 60.96 x 60.96mm)
- Weight: 8.0 oz (227g)
- Temperature: -40 to 150 F (-40 to 65° C)
- Waterproof: Submersible to 33 ft (10m) depth (XPS3), 10ft (3m) depth (XPS2)
- Sealing: Fogproof internal optics
- Color/Finish: Non-reflective black with hard coat finish
- Adjustment (per click): 0.5 MOA (1/2" (12.7mm) at 100 yds (91m))
- Adjustment Range: +/- 40 MOA travel
- Mount: - 1" (25.4mm) weaver or MIL-STD 1913 rail
- Return to Zero: Repeatable to 2 MOA after re-mounting

#### Display Window

- Optical Surfaces: Anti-glare coating
- Window Dimensions: 1.20" x 0.85" (30 x 23mm)
- Window Material: Shatter resistant laminate (3/16" (4.76mm) thick)
- Field of View 100 yds (91m): 30 yds (28m) at a 4" eye relief
- Reticle Options: 0- 65MOA circle with quadrant ticks with 1 MOA aiming dot
  - 1- Single 1 MOA aiming dot (no outer circle)
  - 2- 65MOA circle with quadrant ticks with (2) 1 MOA aiming dots

## Electrical

- Brightness Adjustment Range: 146,000:1 brightest to lowest
- Night Vision Brightness Range (XPS3): 1280:1 with NV switch engaged
- Power Source: 1 x 123 lithium battery
- Battery Life: Approximately 600 continuous hours at nominal setting 12
- Brightness Settings: 30 settings with scrolling feature (10 settings for NV use)
- Auto Battery Check Indicator: Flashing reticle upon start-up
- Auto Shut-down: At 8 hrs- programmable to 4 hrs

## 1.4 Location and Description of Major Components

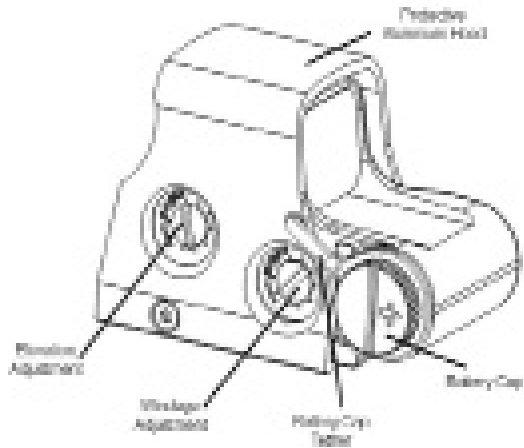

Fig 2: XPS3/XPS2 components

Holographic Window - Contains the embedded holographic reticle pattern that forms a virtual image of the reticle when illuminated by laser light.

Protective Hood - Preassembled, protective hood increases durability of sight housing and protects the sight from impact damage.

Battery Cap- A threaded cap that secures and seals the battery compartment to prevent water, dirt, or grime from entering the battery housing.

Universal Mount - Integrated base to mount to either a 1" (25.4mm) Weaver or MIL-STD-1913 rail.

Windage Adjustment - Adjusts the point of impact  $1/2$  MOA per click in a leftward and rightward direction.

Elevation Adjustment - Adjusts the point of impact  $1/2$  MOA per click in an upward and downward direction.

On/Off, NV Mode, and Brightness Switches - Raised button control interface allows the operator to perform and adjust user settings for appropriate and preferred conditions.



## 2.0 OPERATING INSTRUCTIONS

This section describes the features and operating instructions of the XPS3/XPS2. Please read the instructions carefully before mounting and using the sight, and always practice proper firearm safety.

The HWS will include:

- Sight assembly
- 1 x Type 123 Lithium battery
- Technical Manual

### 2.1 Description of Components, Controls, and Indicators

The HWS uses a laser to illuminate a holographic reticle pattern embedded in the display window and forms a virtual image of a reticle pattern. The shooter looks through the display window and sees a bright red image of a reticle pattern projected onto the target plane. There is absolutely no light projected onto the target plane. The HWS has no magnification.

### 2.1.1 Hood

The HWS is equipped with a protective hood. This hood is pre-assembled at the factory. Should your hood require repair or replacement, please contact your unit armorer for repair, replacement, or contact the manufacturer (L-3 EOTech) for repair or replacement.

### 2.1.2 Battery

One initially supplied (1) 123 Lithium battery powers the XPS3/XPS2 HWS. The HWS is designed to maintain constant brightness at a particular setting as the battery drains down. The reticle brightness will not fade gradually as the battery runs down, but rather, shut down abruptly. The first indication of the battery draining is the reticle blinking when the unit is turned on (see Electronic Features 2.1.4). Another indication of a low battery is the reticle pattern blinking off and on during recoil. With high recoil guns, this can occur before the battery check indicates low battery condition. If the reticle pattern blinks off and on during recoil or turns off suddenly, replace the battery. Please read and follow the battery replacement and battery check procedures described in this Manual. It is always good practice to replace the battery with a fresh one before a mission.

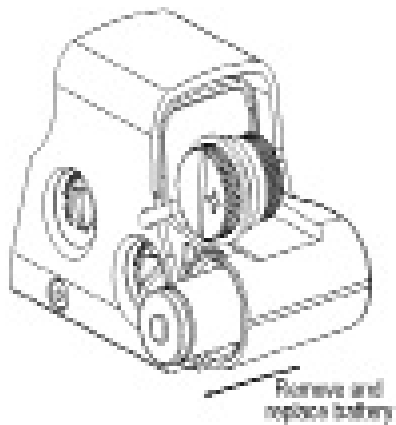

Fig 3: Proper battery Installation

### 2.1.3 Replacing the Battery

Remove the battery cap by turning the cap counterclockwise until the cap pulls away from the battery compartment (Fig. 3). After the battery cap is removed, slide the battery out and replace it with a fresh one. A "+" marking can be found on the top of the battery cap ensuring correct battery orientation. To reinstall the battery cap, align the cap with the battery compartment and carefully begin to thread the cap, turning it clockwise. Before you begin tightening the cap, make sure the threads are aligned correctly to avoid cross threading. Verify correct battery installation immediately by turning on the sight and checking if the holographic reticle appears.

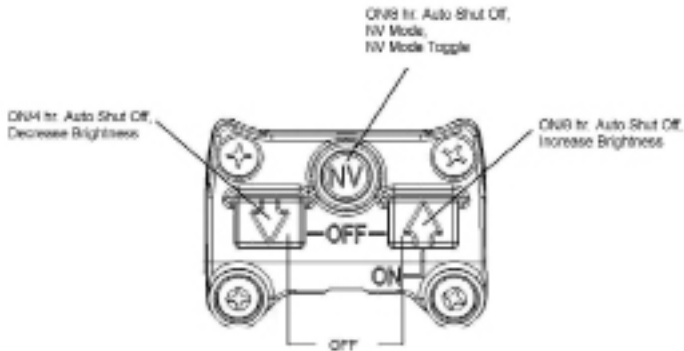

Fig 4: Pushbutton interface

## 2.1.4 Electronic Features

All electronic controls are via pushbutton switches located at the rear of the unit housing as shown in Fig. 4. To ensure proper operation of the pushbutton switches, press firmly on the center of the switch.

### 1. ON/ Auto Battery Check

Pressing the Up or Down Arrow pushbutton switches will turn the sight ON at Level 12. See item 4 under this section for a description of Auto shutdown. The sight will automatically perform a battery check every time it is turned on. The reticle will blink when the batteries have between 2.5 and 5 hours of useful life left.

### 2. OFF

To turn the sight off, simultaneously press both the UP and DOWN arrows. Verify that the sight is on/off by looking through the heads-up display window for the reticle.

### 3. Brightness Adjustment

Pushbutton switches vary the brightness intensity of the holographic reticle pattern. Pressing and releasing the pushbutton switches moves the brightness level UP or DOWN one (1) step from the previous setting. Pressing and holding the UP arrow or DOWN arrow switch will change the brightness level up or down continuously in steps. Twenty (20) brightness settings provide a dynamic range of 146,000:1 from the lowest setting to the highest setting.

#### 4. Auto Shutdown

The HWS has an auto shutdown feature. If the sight is turned on by pressing the UP button, it will automatically shut itself OFF 8 hours after the last pushbutton control is used. The sight will automatically shut OFF after 4 hours if it is turned on by pressing the DOWN button.

## 2.1.5 Night Vision Mode On/Off Auto Shutdown

The XPS3 HWS is compatible with Generation I - III+ Night Vision Devices. At the night vision settings, the reticle brightness is low enough that when viewed with a night vision device, the reticle image does not bloom.

### 1. ON/ Night Vision Mode and 8 Hour Auto Shut Down (XPS3)

Pressing the NV Button (see Fig. 4) will turn the sight ON in Night Vision Mode. The sight will turn on at Level 4 and automatically shut off 8 hours after the last pushbutton control is used. There are 10 brightness settings in NIGHT VISION MODE with a dynamic range of 1280:1.

### 2. OFF/ Turning Sight OFF

To turn the sight off, press both the UP and DOWN arrows simultaneously. Verify that the sight shuts off by looking through the heads-up window with the night vision device.

### 3. TOGGLE/ Between Normal and Night Vision Modes (XPS3)

To toggle between NORMAL and NIGHT VISION MODES, press the NV button. When switching between modes, the sight will remember the last brightness setting. NOTE: When used with a Night Vision device, always check to make sure the sight is not turned on before pressing the NV button to turn on the sight in the Night Vision mode. Otherwise, it will toggle to the Normal mode and saturates the image intensifier.

## 2.1.6 Windage and Elevation Adjustments

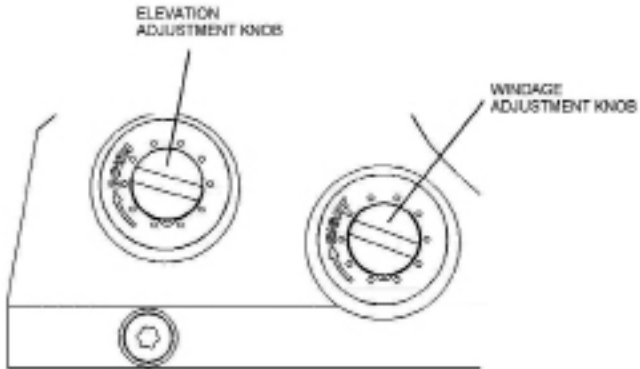

Fig 5: Adjustments

The HWS features click mechanisms for elevation and windage adjustments. The elevation and windage adjustment are located on the right-hand side of the sight (Figure 5). The knob towards the front is the windage adjustment and the knob towards the rear is the elevation adjustment. Both of these adjustment mechanisms are grooved with a slotted screw head and require the use of a screwdriver, coin, or spent brass to turn. The elevation and windage adjustments are



shown in Fig. 5. For both elevation and windage, each click will change the bullet's point of impact 1/2 Minute of Angle (MOA), ¼ inch (6.35mm) at 50 yards (45.7m), or ½ inch (12.7mm) at 100 yards (91m). Also, one full rotation of either knob will change the point of impact 10 MOA, 5 inches (127mm) at 50 yards (45.7m), or 10 inches (254mm) at 100 yards (91m). To move the point of impact UP, turn the elevation adjustment LEFT. To move the point of impact RIGHT, turn the windage adjustment RIGHT.

The HWS elevation and windage adjustments are factory collimated with the bore of the rifle parallel to the mounting rail. The sight should be close to mechanical zero when mounted on a properly installed rail. Do not turn the adjustments before mounting the sight on the firearm. Be sure to check that the mount and sight are securely mounted after initial firing

**CAUTION** – There are 80 minutes of total windage and elevation (40 minutes in each direction) in the HWS. There are 80 1/2 min. clicks of adjustment from optical center to the limits of windage and elevation adjustment. To establish optical/mechanical zero, adjust turrets to limit, then return 80 clicks (do this for both the elevation and the windage). When encountering an increase in resistance in adjustments, the end of the adjustment range has been reached. **DO NOT** turn the adjustments any farther, serious damage may occur to the sight.

## 2.2 Preventive Maintenance Checks and Services (PMCS)

### OPERATOR LEVEL MAINTENANCE

The operator is limited to replacing batteries and cleaning the battery compartment and outer housing surfaces of the sight.

### REPLACING BATTERY

See the heading 'Replacing Battery' under section Description of Components, Controls, and Indicators. Do not use deteriorated or corroded batteries. Inspect battery for rips, tears, or cuts in the housing. If there is any exposed, internal content of the battery, it could potentially effect the operation of the sight.

### OPERATOR CLEANING INSTRUCTIONS

1. The optical system and the window are coated with anti-reflection material. When cleaning the glass surfaces, first blow away any dirt and dust. Fingerprints and lubricants can be wiped off with lens tissue or a soft cotton cloth, moistened with lens cleaning fluid or glass cleaner sold in any camera store. Never clean the glass surface with a dry cloth or paper towel; always dampen the glass surfaces prior to cleaning.

2. No maintenance is needed on the sight's surface, except to occasionally wipe off with a soft cloth. Use only a water-based cleaner such as glass cleaner, ammonia, or soap and water. Never use any solvent-type cleaner such as alcohol or acetone. Do not use gun cleaner to clean or lubricate the HWS.

3. All moving parts of the sight are permanently lubricated. Do not try to lubricate them.

4. Never disassemble the sight's optical assembly! The optical cavity is purged, nitrogen filled, and sealed to achieve fog proof performance. Disassembly will void the warranty and damage the sight.

### 2.3 Troubleshooting

The following section outlines measures the operator can take in the event of the named failure.

Failure: The sight will not power up:

Corrective Action 1: Ensure the battery is inserted properly. The positive (+) end should be positioned on the side of the battery cap.

Corrective Action 2: Replace the battery with a new, unused battery that contain a full charge.

Corrective Action 3: Inspect the battery contact points in both the battery cap and in the sight itself. Ensure that they are free of debris or corrosion.

Corrective Action 4: Reset the electronics by removing any source of power for approximately two minutes. This will allow a capacitor in the electronics housing to drain of power, resetting the electronics. Reinstall the battery and operate the sight as normal.

Corrective Action 5: Check the battery contacts for corrosion or wear. Clean the contacts.

Corrective Action 6: Turn in the sight for unit level maintenance.

Failure: The reticle is fuzzy/ has a 'halo' effect/ has more than one reticle:

The reticle is naturally pixilated and the outer circle will appear to be made up of many small dots. The center circle will still be distinguishable as one dot.

Corrective Action 1: Lower the brightness level of the reticle. This fault is generally caused by the reticle brightness being too high. The reticle is not designed to be so bright as to block the target.

Corrective Action 2: The reticle is projected onto your target plane. You must focus on it like you would any other object at that distance. Do NOT focus on the sight housing, rather, focus on your target. The outer ring is designed to be a reference to center, similar to a ghost ring.

Corrective Action 3: If you wear corrective lenses for nearsightedness, you will require them to see the reticle in focus, as it is projected onto the target plane. If you wear bifocals or have astigmatism, you may see a distorted reticle.

Corrective Action 4: Check with others who have used the sight, and compare what you see to ensure it is not your focal acuity prior to turning the sight in for repair.

Corrective Action 5: Turn the sight in for unit level maintenance.

Failure: The reticle is flashing/ flashing on and off/ unit turns off during recoil:

Corrective Action 1: This is the low battery indicator. Replace the battery.

Corrective Action 2: If the battery is low, a high recoil weapon platform can cause the reticle to flash on and off, even before the low battery indicator takes effect. Replace the battery.

Corrective Action 3: Replace the battery with an Energizer brand battery. These have proven to be the most effective to withstanding a consistent amount of recoil. Many brands of batteries deteriorate faster than others and can result in these failures.

Corrective Action 4: Turn the sight in for unit level maintenance.

Failure: There is a streak in the reticle/ the reticle is dim/ the reticle fades in parts of the window:

Corrective Action 1: Replace the battery.

Corrective Action 2: Check with others who have used the sight, and compare what you see to ensure it is not your focal acuity prior to turning the sight in for repair.

Corrective Action 3: Turn in for unit level maintenance.

Failure: I am missing a bolt/ have broken a bolt/ have broken a latch:

Corrective Action 1: Turn the sight in for unit level maintenance.

## 2.4 Unit Level Maintenance and Repair

The Unit Armorer or individual responsible for unit level maintenance is only authorized to replace or repair the following items:

- Battery
- Battery Cap
- Protective Hood and Hood Screws
- Technical Manual
- Knurled weaver bolt

Please see Additional Authorized Items in Appendix A for the corresponding NSN numbers for the above listed components.

If the sight has been turned in for unit level maintenance that requires action in addition to the above mentioned authorized repair or replacement items, the sight will need to be returned to the manufacturer for the repair.

Contacting the manufacturer for repair:

1. Visit the manufacturer's website at <https://www.L-3com.com/eotech>. Click on the Customer Service Tab in the menu bar and follow the instructions.

2. Call or email L-3 EOTech's Customer Service Department at the following:  
(734) 741-8868 x2178  
[general@L-3com.com](mailto:general@L-3com.com)
  
3. Be sure to leave a name, contact number, return shipping address, and failure description in the email or on a voice mail. This will allow the manufacturer to generate a Return Authorization Number (RA#) to include with the sight(s). DO NOT SHIP THE SIGHTS WITHOUT A RETURN AUTHORIZATION NUMBER (this will severely delay the turn around time on repair or replacement).
  
4. If you require, fill out a DD Form 1149 to include with the sight(s) you will return. Include a reference to the RA#, and a signature line for L-3 EOTech's Service Department to sign indicating the receipt of materials. The signed copy will be mailed, faxed, or emailed back to you upon receipt of the sight(s) for the purposes of accountability.
  
5. If the manufacturing date located on the bottom of the sight is more than two years old, a fee will be assessed for repair to include the cost of both parts and labor. A purchase order will be required to process the repair. Please contact L-3 EOTech for an estimate.

Please send the unit postage prepaid, to address listed in Appendix B. Please include your name, address, telephone number, and a written description of the problem you are encountering, and also include the RA #. Whenever possible, ship the sight in its original box.



## 2.5 Installation of Equipment

### MOUNTING

The HWS is equipped with mounting hardware to attach to a 1" (25.4mm) Weaver or MIL-STD-1913 Picatinny style rail. To achieve the best results and accuracy, the HWS must be mounted properly. The rail needs to be as parallel as possible to the bore to permit the maximum elevation and windage adjustments. If it is required, it is strongly recommend that the rail be installed by a qualified gunsmith. To mount the sight, please follow these steps.

Turn the Knurled Weaver bolt counterclockwise to back the bolt out of the weaver lock. Do not back the bolt all of the way out of the lock, only enough for the base to sit properly on the rail. Turn the Knurled Weaver bolt clockwise, drawing the weaver lock into the rail until resistance is felt. Using a coin, (a U.S. nickel or similar size is recommended), rotate the bolt head an additional  $\frac{3}{4}$  turn to fully tighten. This is equivalent to approximately 17 in-lb (0.2 kgm) of torque.

## 2.6 Zeroing Procedures

Once the weapon's iron sights have been zeroed, please refer to the section on Windage and Elevation Adjustments (Section 2.1.6) to zero the HWS. The following are some additional reference aids that can be used during the zeroing process.

## BORE SIGHTING

Bore sighting is a good preliminary procedure in achieving proper alignment of your sight to the firearm. A chamber laser/ bore sighter is an aid in achieving collimation.

### LIVE FIRE SIGHTING FOR AN M-4 OR M-16

To employ the aiming dot of the HWS reticle from 10 to 300 meters, the sight can be zeroed at 25 meters using a standard M4/M16 military zeroing target. With the dot aimed at center mass of the target, the sight should be adjusted so the round lands approximately 1 cm below the point of aim at 25 meters. This method of zeroing ensures hitting a target at 100-200 meters where fine tuning should be conducted.

Additionally there are custom targets for 25m zeroing used with the M-4 and M16 (see Figure 6), and for Laser Bore Sighting (see Figure 7). Please visit the manufacturer's website at [www.L-3com.com/eotech](http://www.L-3com.com/eotech) or contact the manufacturer for copies of these targets

10m Boresight M16A4/M4MWS EoTech Holographic Sight, top rail

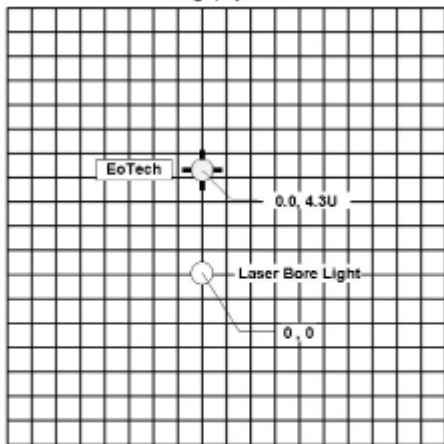

Zero Target Data for  
M16A4/M4MWS

10m Bore Sight Target for 300m Zero  
(25 Sept 2003)

US Army ARDEC  
AMSTA-AR-CCL-A  
AMSTA-AR-F3F-R  
Picatinny Arsenal, NJ 07806

Grids are 1cm wide by 1cm high. Units must locally manufacture.

Fig. 6: M-16/M-4 ZERO TARGET

M16A4/M4MWS with EoTech Holographic Sight, top rail

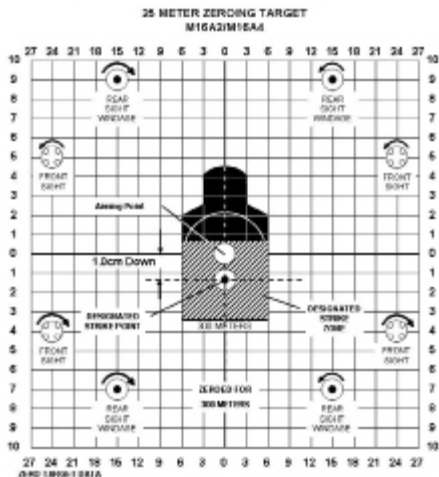

1. FOR ZEROING AT 25 METERS, ROTATE THE REAR SIGHT ELEVATION knob TO THE 300 METER SETTING, THEN CLOCKWISE (CW) ONE CLICK PART THE 300 METER SETTING FOR M16A4 FILE, CLOCKWISE (CW) TWO CLICKS PART THE 300 METER SETTING FOR THE M4MWS FILE.
2. SEE ALL TARGETS CORRECTLY, ADJUST SIGHTS TO BRING SIGHT GROUP CENTER AN EQUAL AS POSSIBLE TO THE WHITE DOT IN THE CENTER OF TARGET.
3. AFTER COMPLETING THE 25 METER ZERO, ROTATE THE REAR SIGHT ELEVATION knob COUNTER-CLOCKWISE DOWN ONE CLICK TO THE 300 METER SETTING FOR THE M16A4 FILE, DOWN TWO CLICKS TO THE 300 METER SETTING FOR THE M4MWS FILE. THE MEANWHILE BE ZEROED FOR 300 METERS.

Fig. 7: Laser Bore Sight for M4/M16

## USING THE 2-DOT BALLISTIC RETICLE

The XPS3/XPS2 offers a unique 2-dot ballistic reticle assisting in short to long range applications. The 2 dots can be distinguished with or without magnification. This simple design is calibrated to the specific trajectory of the M4 carbine but can work on many other weapon platforms. See figure 8.

LOAD	CENTER DOT FIRST ZERO	CENTER DOT SECOND ZERO	SECOND DOT ZERO	BOTTOM OF CIRCLE
<b>.223 Cal.</b> 82 Gr., 2900 Vel.	50 yds	200 yds	500 yds	7 yds
<b>-.44 Mag.</b> 240 Gr., 1300 Vel.	25 yds	50 yds	155 yds	-
<b>12 Ga. Sabot</b> 385 Gr., 1890 Vel.	25 yds	100 yds	250 yds	-
<b>.50 Cal. Black Powder</b> 390 Gr., 1880 Vel.	25 yds	100 yds	250 yds	-

Figure 8 Ballistic Chart

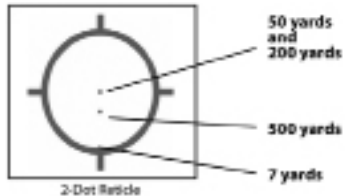

Figure 9 (2-dot reticle for a .223)

### 3.0 APPENDIX A: Components of End Item

#### 3.1 REPLACEMENT ITEMS

<u>Part number</u>	<u>Description</u>	NSN(for GSA orders)
XP1100	Threaded Battery Cap – 123 Lithium Battery	n/a
XP2081	Battery cap tether	n/a
XP2053	Hood For XPS3/XPS2	n/a
N1101	Hood Screws (3 screws)	n/a
CR7751	123 Lithium Battery (1 battery)	n/a
XP2096	Knurled Weaver Bolt	n/a
XP1950	XPS User Manual	n/a

#### 4.0 APPENDIX B: Factory Contacts

Customer Service/Repair.....888-EOTHOLO  
(734) 741-8868

Technical Sales/Service .....(734) 741-8868 x2178

Shipping Address:

L-3 EOTech Inc.  
1201 E. Ellsworth Rd.  
Ann Arbor, MI 48108  
USA

EMAIL.....general@L-3com.com

Visit us on the web .....www.L-3com.com/eotech

**OUR PRODUCT IS PROUDLY MANUFACTURED IN THE UNITED STATES OF AMERICA**



