

- Parts List**
1. Receiver
  2. Rear Sight Assembly
  3. Barrel
  4. Front Sight
  5. Gas Cylinder with Stacking Swivel
  6. Gas Cylinder Lock
  7. Gas Cylinder Lock Screw
  8. Operating Rod
  9. Clip Latch
  10. Clip Latch Pin
  11. Clip Latch Spring
  12. Rear Handguard Band
  13. Lower Band
  14. Lower Band Pin
  15. Rear Handguard (wood)
  16. Stock (wood)
  17. Front Handguard (wood)
  18. Front Handguard Ferrule
  19. Stock Ferrule & Swivel
  20. Butt Swivel
  21. Buttplate & Screws
  22. Bolt
  23. Extractor
  24. Extractor Spring
  25. Extractor Plunger
  26. Ejector Spring
  27. Ejector
  28. Firing Pin
  29. Slide & Follower
  30. Bullet Guide
  31. Operating Rod Catch
  32. Accelerator
  33. Accelerator Pin
  34. Follower Arm
  35. Follower Rod
  36. Operating Rod Spring
  37. Follower Arm Pin
  38. Trigger Housing
  39. Trigger Pin
  40. Hammer Pin
  41. Safety
  42. Trigger Guard
  43. Clip Ejector
  44. Trigger
  45. Hammer
  46. Hammer Spring Housing
  47. Hammer Spring
  48. Hammer Spring Plunger

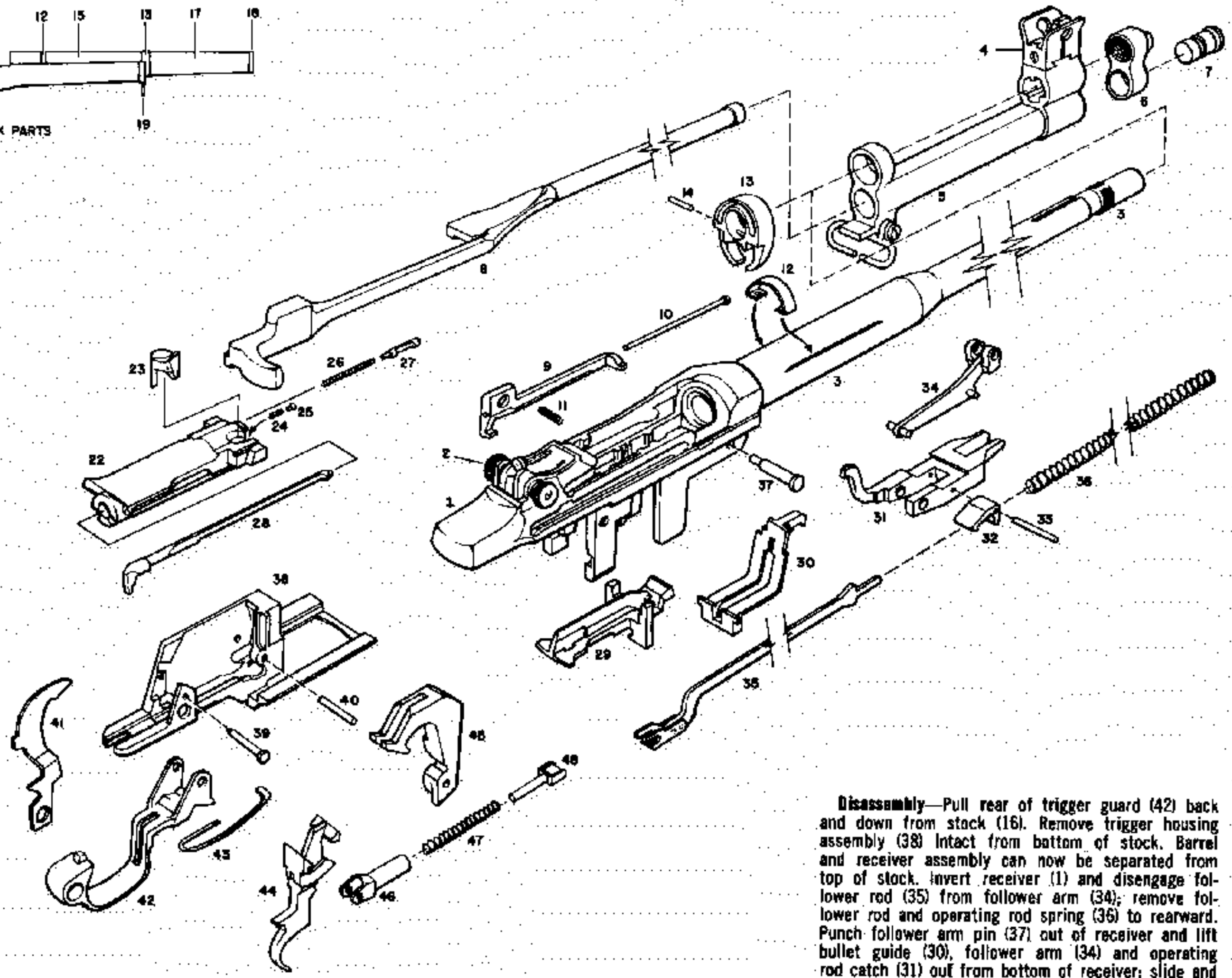

**U.S. RIFLE CAL. 30. MI  
(Garand)**

**Disassembly**—Pull rear of trigger guard (42) back and down from stock (16). Remove trigger housing assembly (38) intact from bottom of stock. Barrel and receiver assembly can now be separated from top of stock. Invert receiver (1) and disengage follower rod (35) from follower arm (34); remove follower rod and operating rod spring (36) to rearward. Punch follower arm pin (37) out of receiver and lift bullet guide (30), follower arm (34) and operating rod catch (31) out from bottom of receiver; slide and follower (29) may then be lifted out bottom of receiver. Pull operating rod (8) to rear, pulling rod up and away from receiver to disengage it from bolt (22); then pull it down and backward to withdraw from receiver. Slide bolt (22) forward while lifting upward and outward with a rotary motion to remove from receiver. Reassemble in reverse order.